

V6W0000

Six Ways Ball Valves for Terminal Units

Product Bulletin

The V6W0000 line consists in six-way ball valves used for HVAC 4 pipes applications to automatically carry out the winter-summer change-over or, potentially, the control of radiant ceilings, fan coils and chilled beams.



- No cross-flow between floating and cooling circuits.
- Different K_{vs} combination for an accurate and valuable control.
- Compact and economical solution.
- Changeable disk to select K_{vs} on site, avoiding any possible ordering mistakes.

Application

The new six-way ballvalve comes out of the big experience gained over many years that experts have spent working on many air conditioning projects all-over the Europe. The wider and wider realization of 4 pipes conditioning systems and technical/practical issues to move simultaneously by actuators two or four valves have pushed technicians to look for compact, reliable and easier solutions like the V6W0000 six-way ballvalve.

The simultaneous 90° rotations of the two balls, moved just by one stem, opens supply and return ways on one side (for example, ways n. 1 and n. 4) and closes at the same time the other side (ways n. 5 and n. 6). It avoids any mixing between flows.

For its suitable operation, the six-way ballvalve has to be equipped with Johnson Controls electric rotary actuators. The electric actuator makes the change-over automatic. It also allows the control of the water flow by means of a local (room thermostat) or centralized (BMS) device.

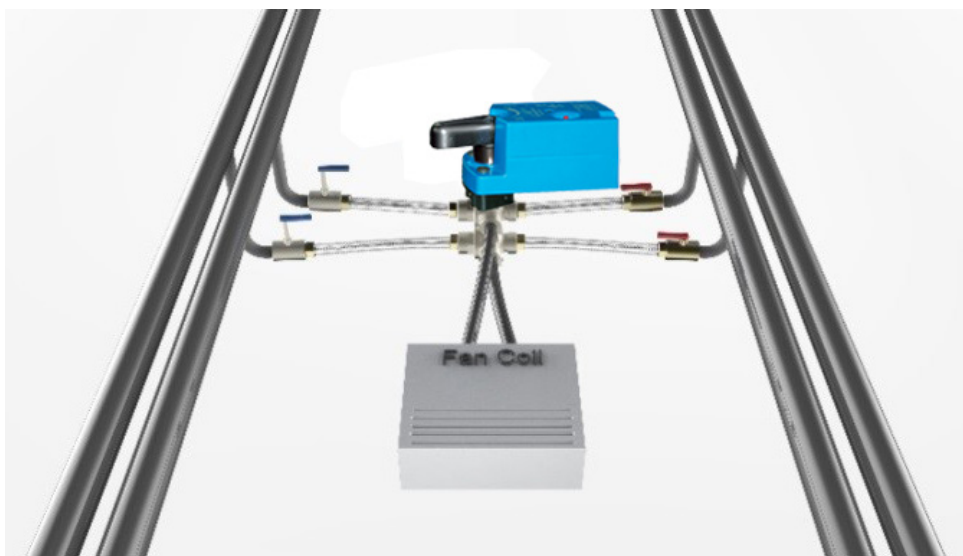

Valve Operation

The valve is equipped with two balls with an "L" hole. A reference sign made by laser is placed on the main stem; ball position is univocally and immediately identified by this sign even once the valve is installed.

Here below the diagram shows the characteristic operation curve of the six-way valve with the stem/balls rotation.

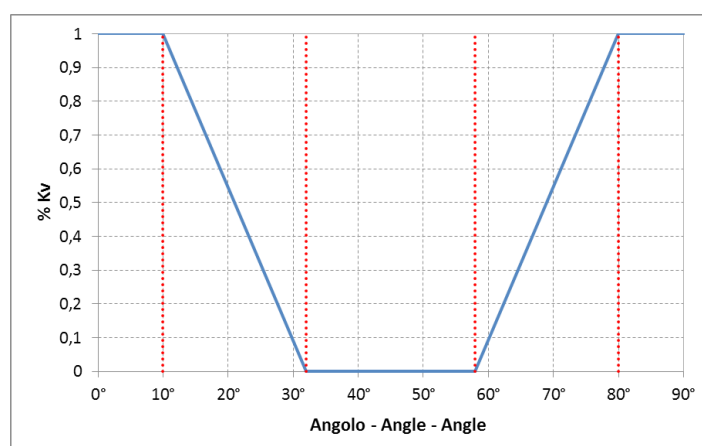
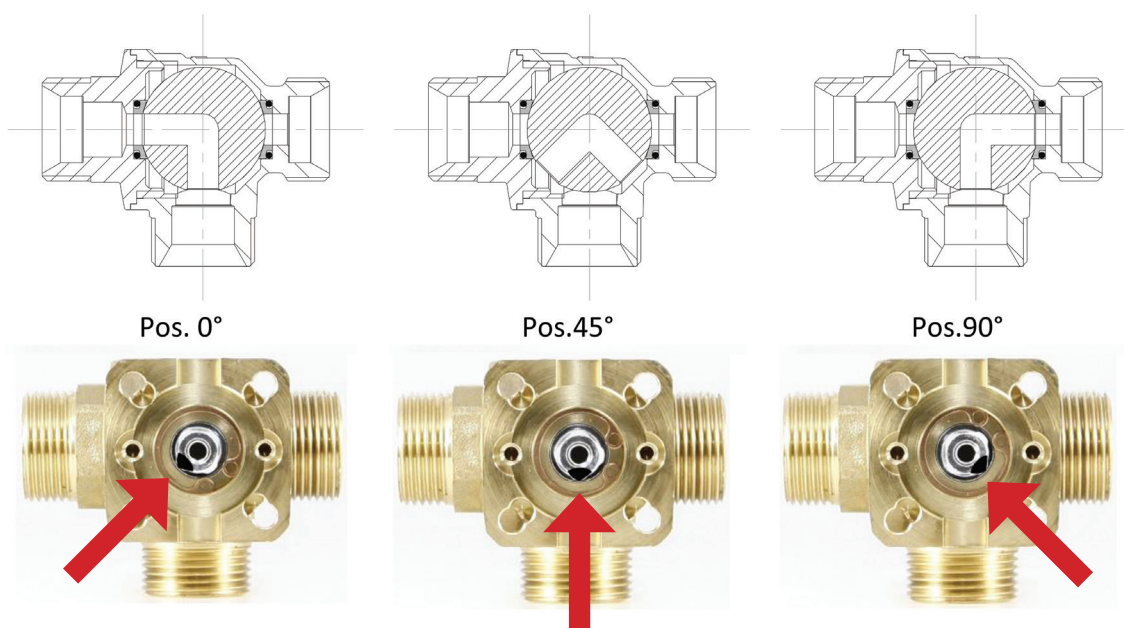

For a correct installation, strictly respect flow directions, as reported by the picture below. The milling sign on the main stem indicates the current ball position, as above-mentioned.

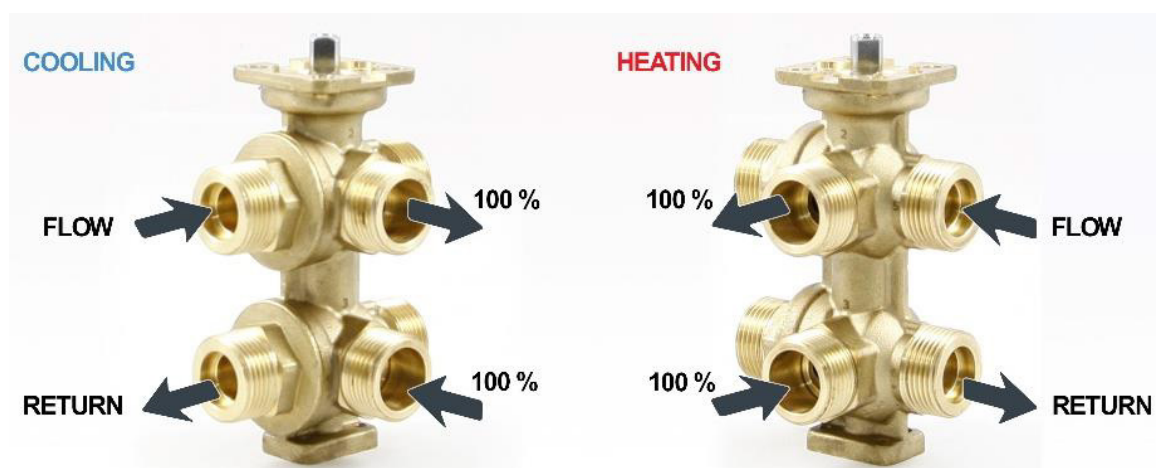

K_{vs} Value Selection

In order to simplify the logistic and the installation in the building site, the valve is supplied with the maximum K_{vs} , or flow rate, configuration on both sides. Our fieldwork experience tells us heating and cooling flow rates are different because they are related to the project ΔT . Very often, the heating flow rate is smaller compare to the cooling one: the cooling ΔT is lower. Hence the choice to give a standard kit together with the valve: this kit involves 4 couples of changeable discs made by PSU. The final user can select the suitable K_{vs} for each side by changing the disc. The kit is included in the valve box.

The K_{vs} value is written on the internal side of every disc. The installer, following the designer guidelines, picks adequate discs out for two sides. This expedient ensures high flexibility and practicality.

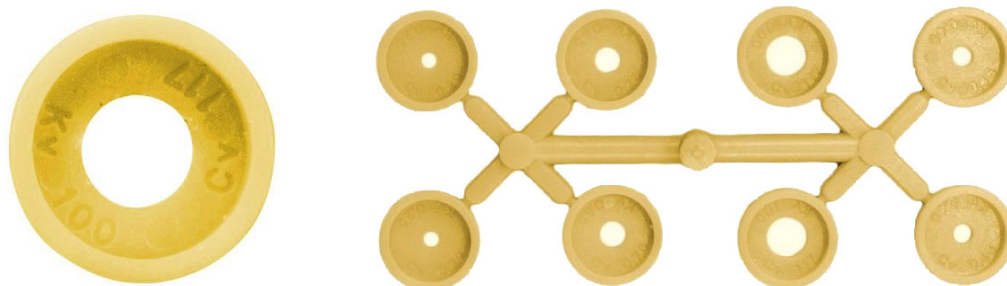

It is strongly suggest to place the discs for K_{vs} management on the return ways, namely on the ways number 4 and 6. If any mistake is made throughout the installation of discs, the wrong one can be taken away using a two nole wrench, like the picture beside.



The diagram shows pressure losses of one side of V6W0000 valve according to the chosen K_{vs} value (or disc). The pressure drop behavior of the other side is equal.

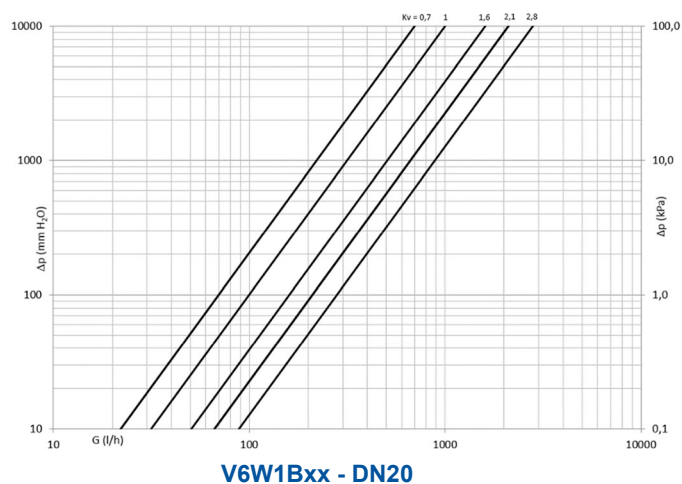
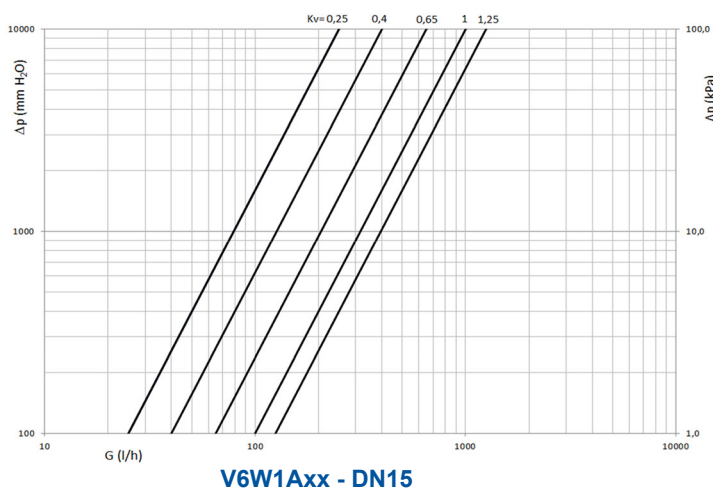

Ordering Codes and Dimensions (in mm)

Ordering Codes	Body Size	Kvs max	Kvs with disk	Connection	Actuator
V6W1AAE	DN15	1,25	1 - 0.63 - 0.4 - 0.25	3/4" Male Flat ends	VA9104-GGA-1S
V6W1BCF	DN20	2.7	2.1 - 1.6 - 1.0 - 0.7		VA9310-HGA-1

The following codes can be manufactured on demand:

Ordering Codes	Body Size	Kvs max	Kvs with disk	Connection
V6W0AAE	DN15	1,25	1 - 0.63 - 0.4 - 0.25	½" Female BSP
V6W2AAE	DN15	1,25	1 - 0.63 - 0.4 - 0.25	3/4" M Eurocone
V6W3AAE	DN15	1,25	1 - 0.63 - 0.4 - 0.25	3/4" M 60° BS5200

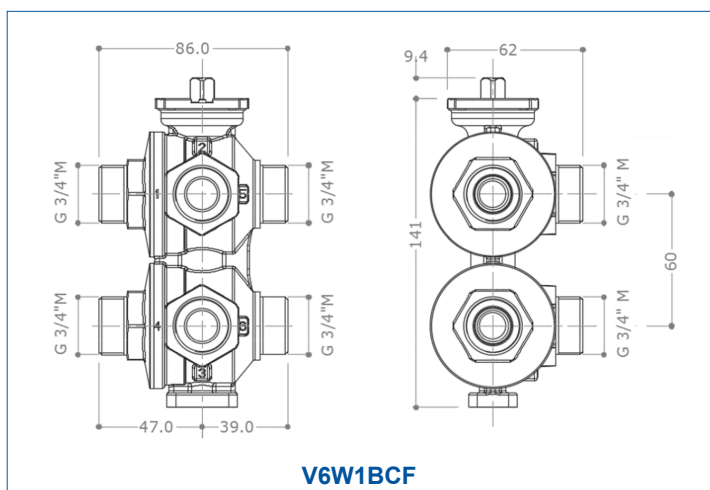
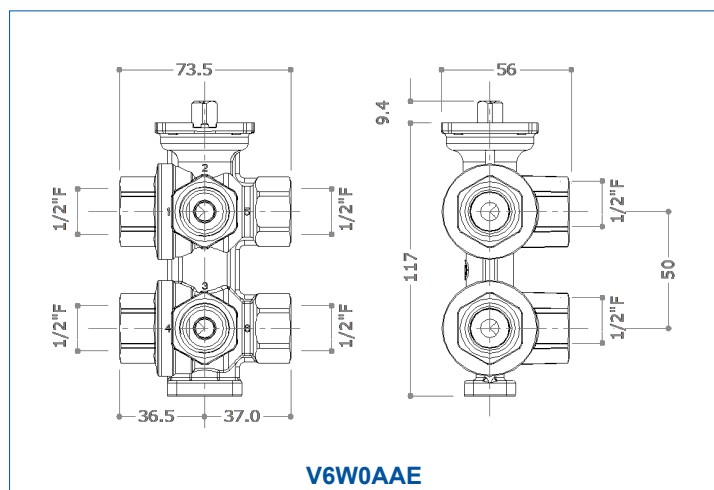
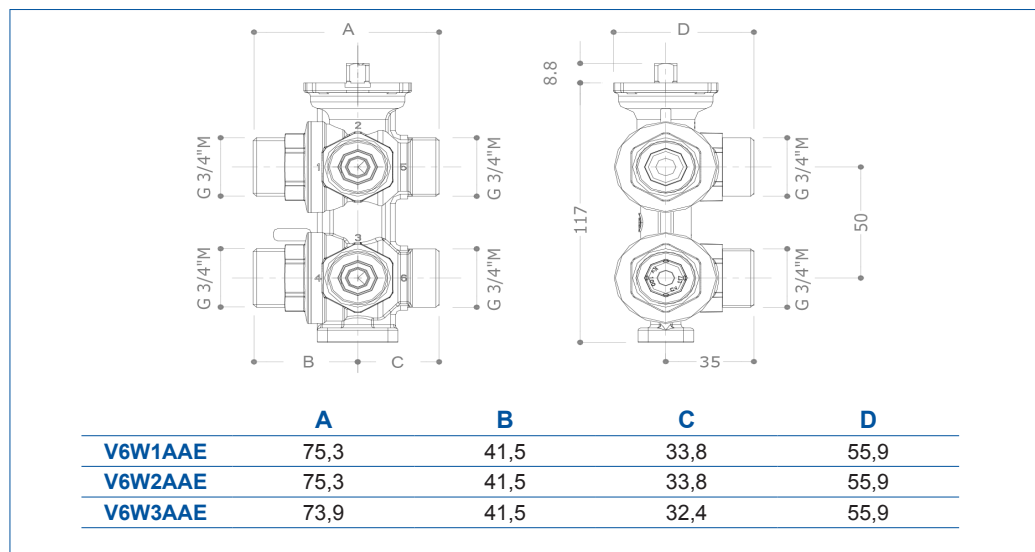

Structure and Components

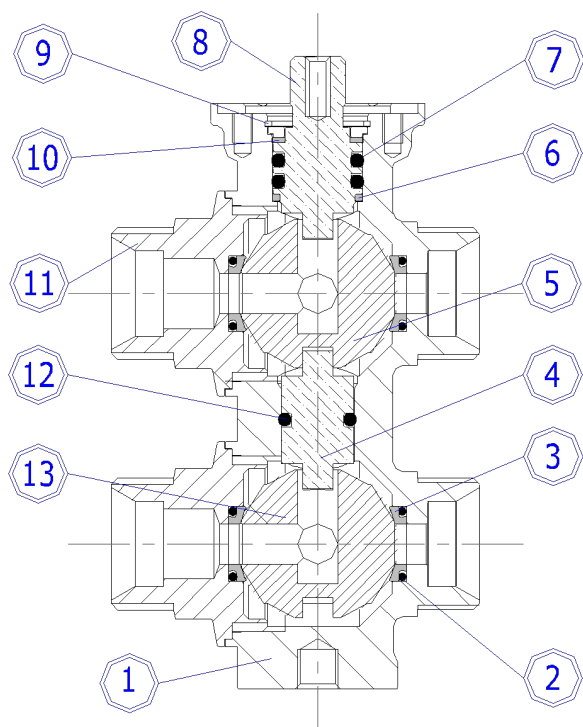

V6W0000

1	Body	CW602N (EN 12167) CuZn36Pb2As
2	O-ring	EPDM - Perox
3	Seats	PTFE
4	Stem	CW614N (EN 12164) CuZn39Pb3 chrome plated
5	Ball	CW614N (EN 12164) CuZn39Pb3 chrome plated
6	Antifriction seat	PTFE
7	O-ring	EPDM - Perox
8	Main stem	CW614N (EN 12164) CuZn39Pb3 chrome plated
9	Seeger	Phosphor bronze
10	Antifriction seat	PTFE
11	End connection	CW602N (EN 12167) CuZn36Pb2As
12	O-ring	EPDM - Perox
13	Ball	CW617N (EN 12164) CuZn40Pb2 chrome plated

Technical Specifications

	V6WAxx	V6WBxx
Handled fluid	Water (glycole max 50%)	
Min water temperature	-10 °C	
Max water temperature	120 °C	
Nominal pressure	16 bar	
Characteristic curve	Linear -	
Kvs max	See Ordering codes	
Kvs	See Ordering codes	
Connections	See Ordering codes and Dimensions paragraphs	
Nominal diameter	See Ordering codes and Dimensions paragraphs	
Total operation angle	90°	
First side operation angle	0-32°	
“Dead zone” operation angle	32°-58°	
Second side operation angle	58°-90°	
Max differential pressure	2 bar	
Leakage level	EN12266-1/12 P12 cl. A	
Weight of the valve	1020 g	1880 g
Water quality	UNI 8065 - Fe<0.5mg/kg - Cu<0.1 mg/Kg	
Compliance	<p>Fratelli Pettinaroli S.p.A., declares that these products are in compliance with the essential requirements and other relevant provisions of the PED (Pressure Equipment Directive) 23/97/CE (Paragraph 3, comma 3)</p> <p>CE marking is not applicable.</p> <p>ROHS</p>	

Accessories

FASTENING ANGLE

Ordering Code 063ZA

The base of the six-way valve has an integral base with 4 threaded holes M4. The base can be easily fixed to a specific angle (item **063ZA**). In this way the six-way valve makes the installation easier.

The valve can be fixed to walls and ceilings by means of that angle. Angle installation is easy thanks to two buttonholes on the vertical side. The valve can be fixed on the horizontal part using the specific holes: suitable M4 screws are included in the angle packing. In case of different installation, a threaded M8 hole, placed in the center of the integrated base, can be used.

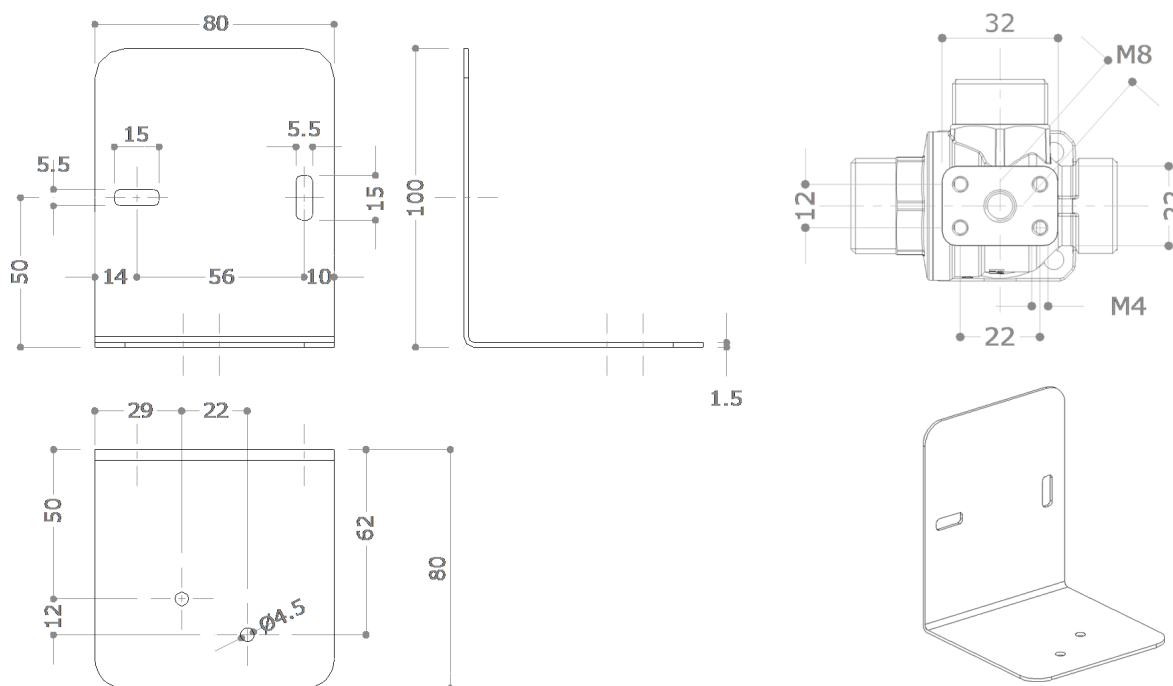

INSULATING CASE

Ordering Codes

063GI-DN15	Insulating case for DN15 valves
063GI-DN20	Insulating case for DN20 valves

In order to ensure the thermal insulation of the six ways valves, the insulating case is available as optional (to be purchase separately). The case can be installed even when the valve is already connected to pipes.

