

VISTA FRONTALE
TOP VIEW

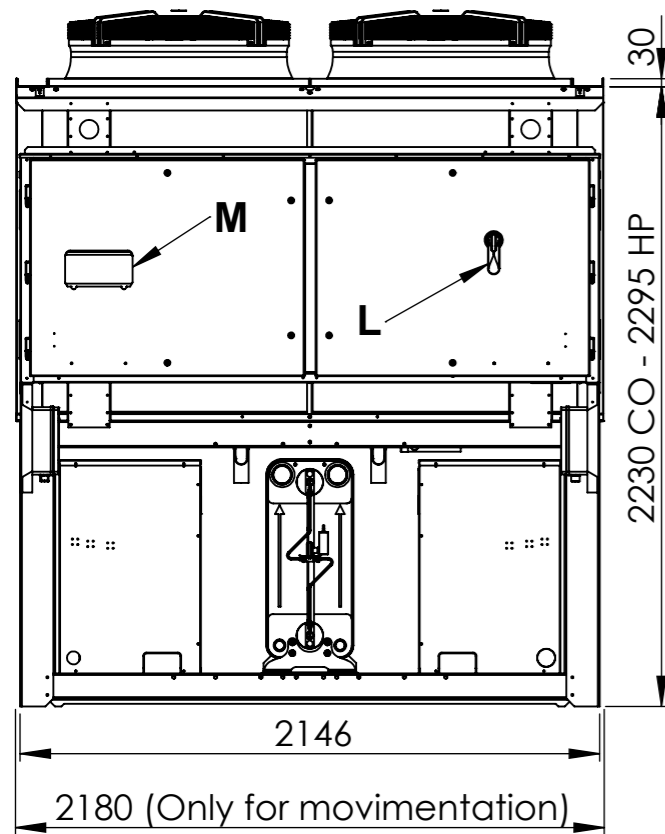

VISTA LATERALE
SIDE VIEW

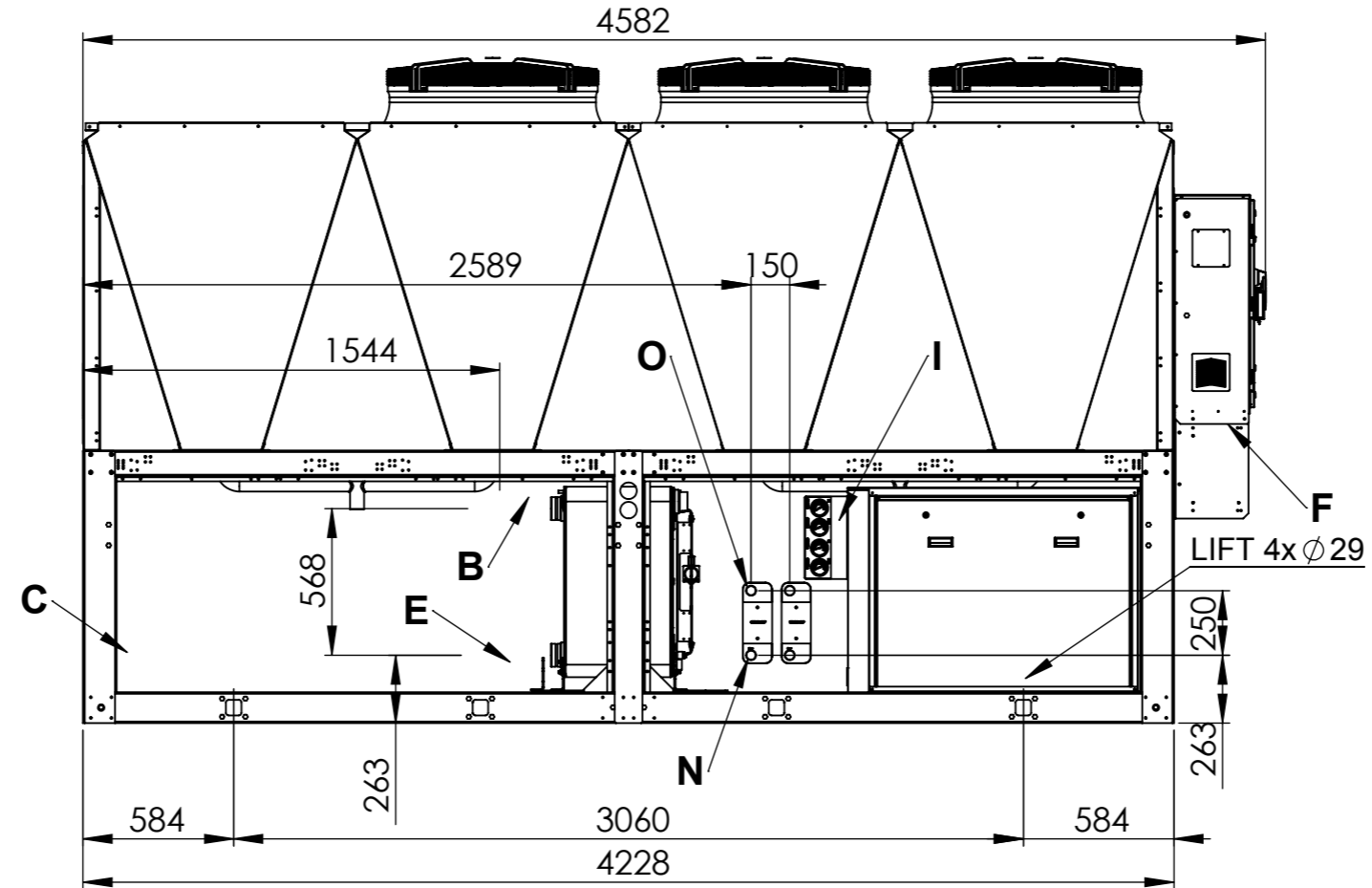

VISTA POSTERIORE
BACK VIEW

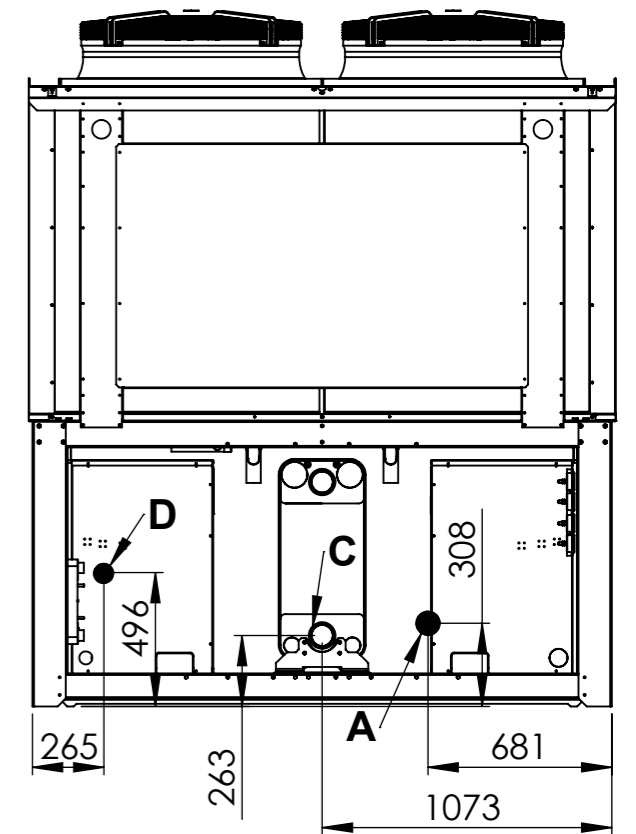

YLRA 360

RE VERSION

CIRCUIT 1

- Q- Ø 7/8" liquid circ.1
- R- Ø 1 5/8" suction circ.1

CIRCUIT 2

- S- Ø 2 1/8" suction circ.2
- T- Ø 1 1/8" liquid circ.2

NOTES:

- A B C D E-WATER CONNECTION 3" GAS M Ø 88,9mm
- F - ELECTRICAL POWER SUPPLY
- I - GAUGE KIT (ACCESSORY)
- L - MAIN SWITCH
- M - CONTROL KEYPAD / DISPLAY

OPTIONAL

- N- DESUPERHEATER WATER INLET Ø 1" GAS M
- O- DESUPERHEATER WATER OUTLET Ø 1" GAS M

P1, P2, P3, P4 AVM POSITION

VISTA DALL'ALTO
BOTTOM VIEW

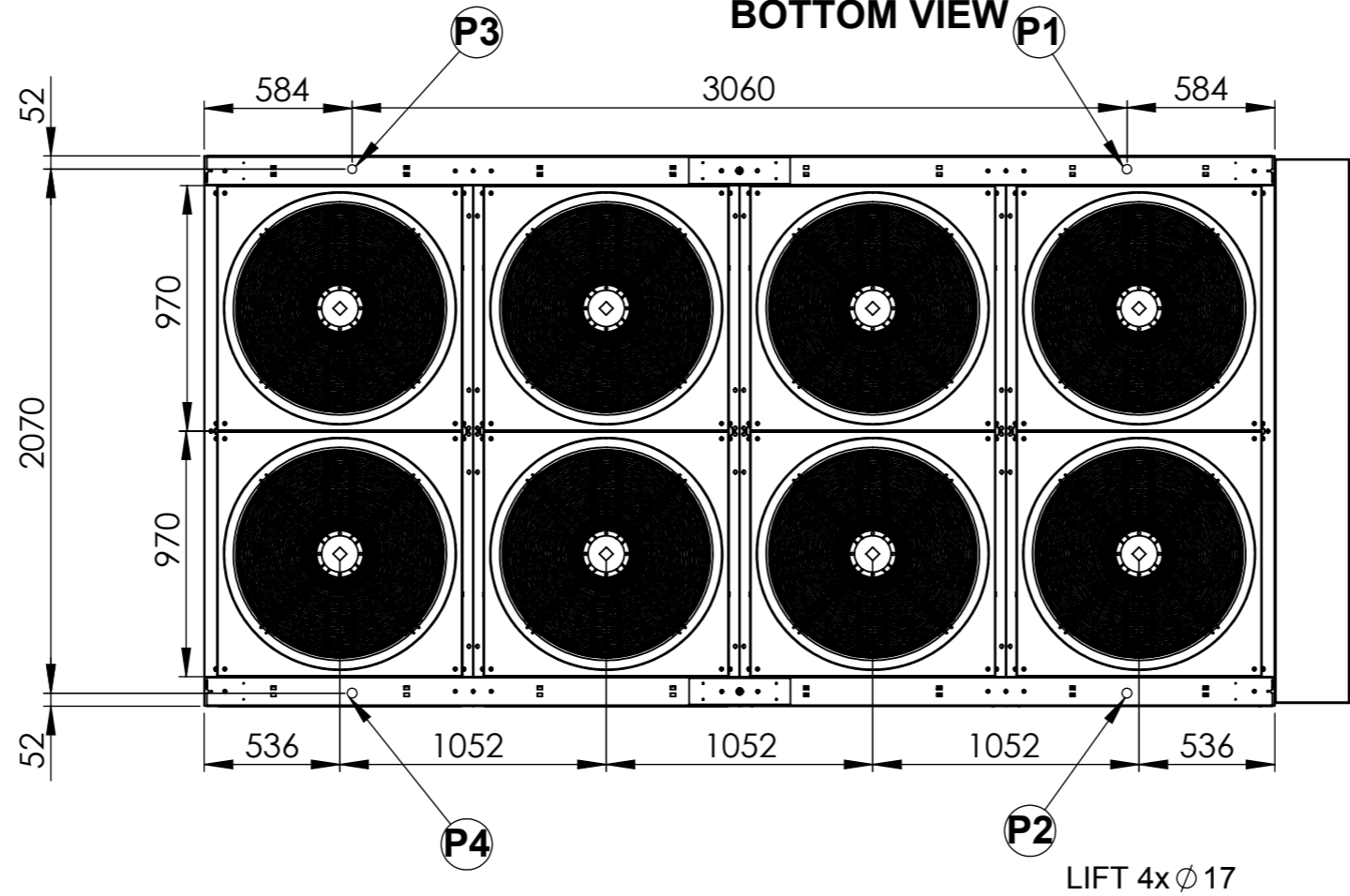

VISTA POSTERIORE VERSIONE RE
BACK VIEW RE VERSION

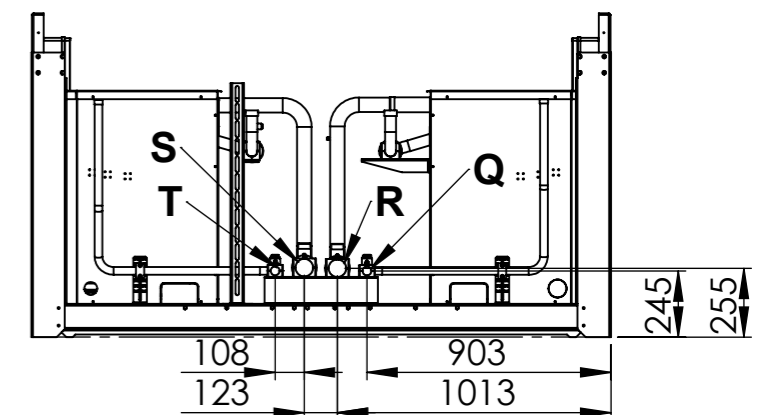

HYDRAULIC OPTION	WATER IN	WATER OUT
STD	B	E
1P/2P	A	C
1PT/2PT	A	D