

VISTA FRONTALE
TOP VIEW

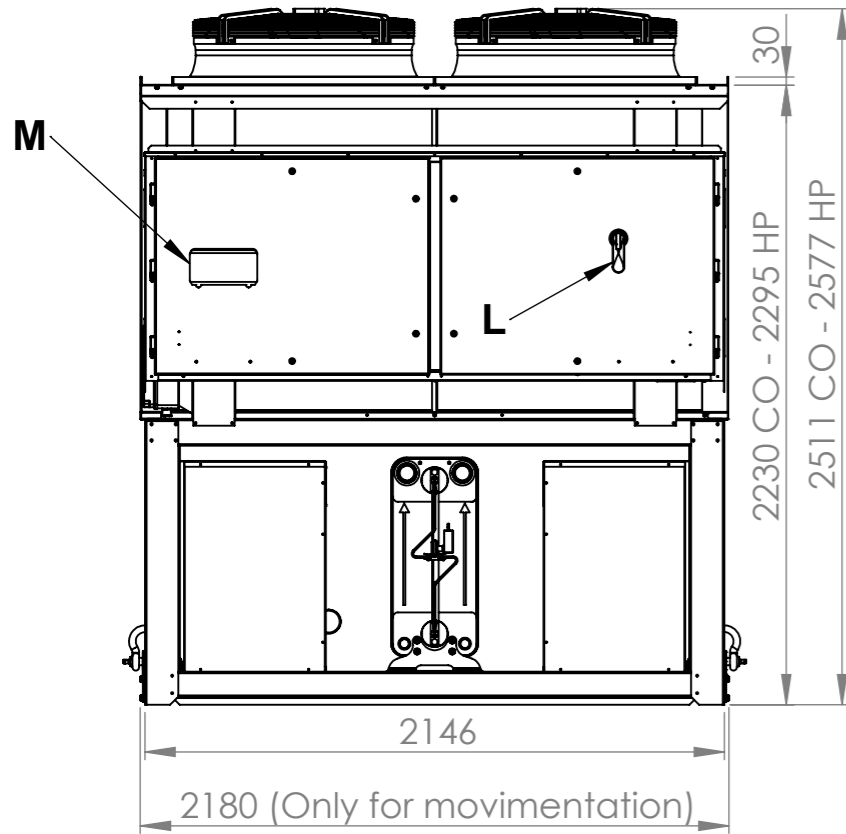

VISTA LATERALE
SIDE VIEW

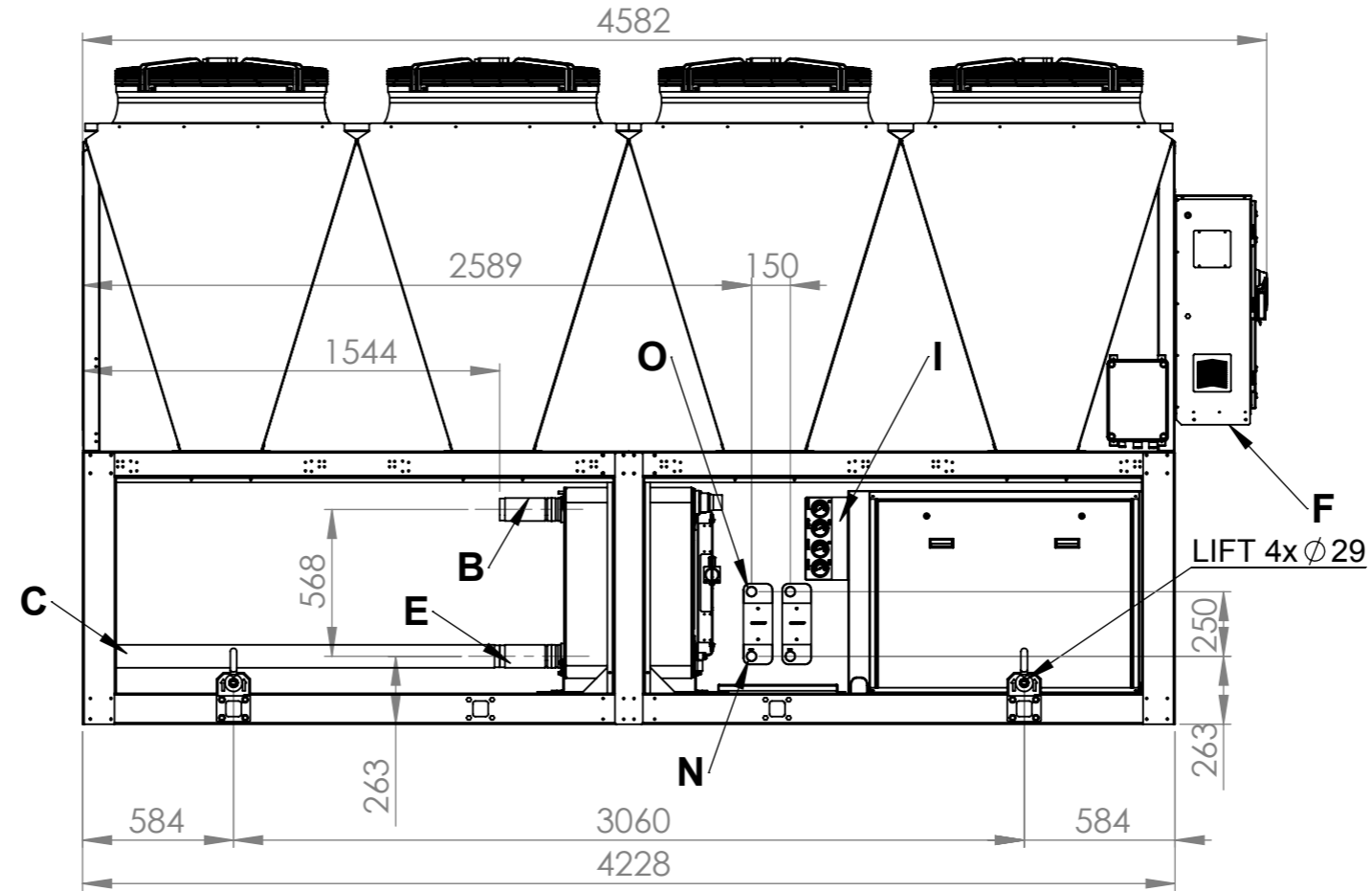

VISTA POSTERIORE
BACK VIEW

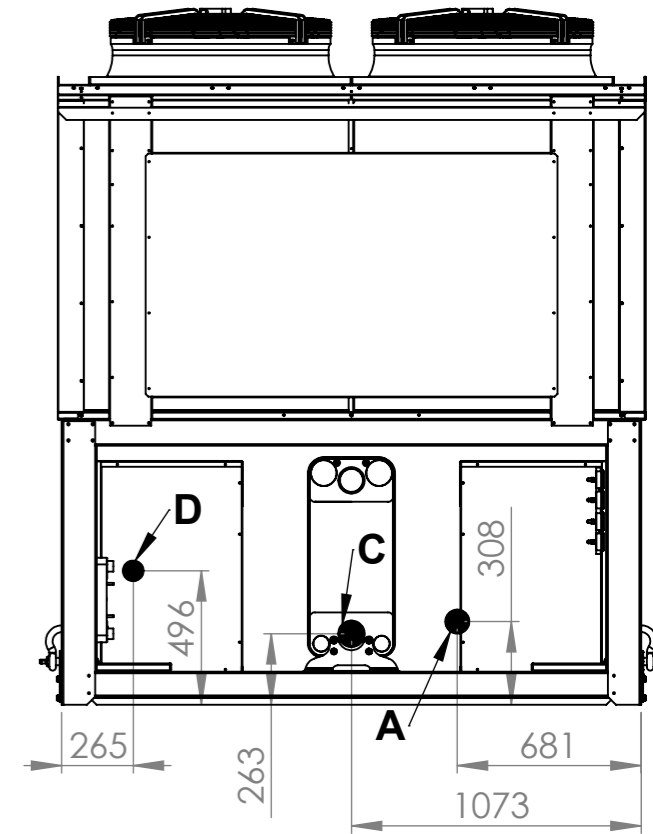

VISTA DALL'ALTO
BOTTOM VIEW

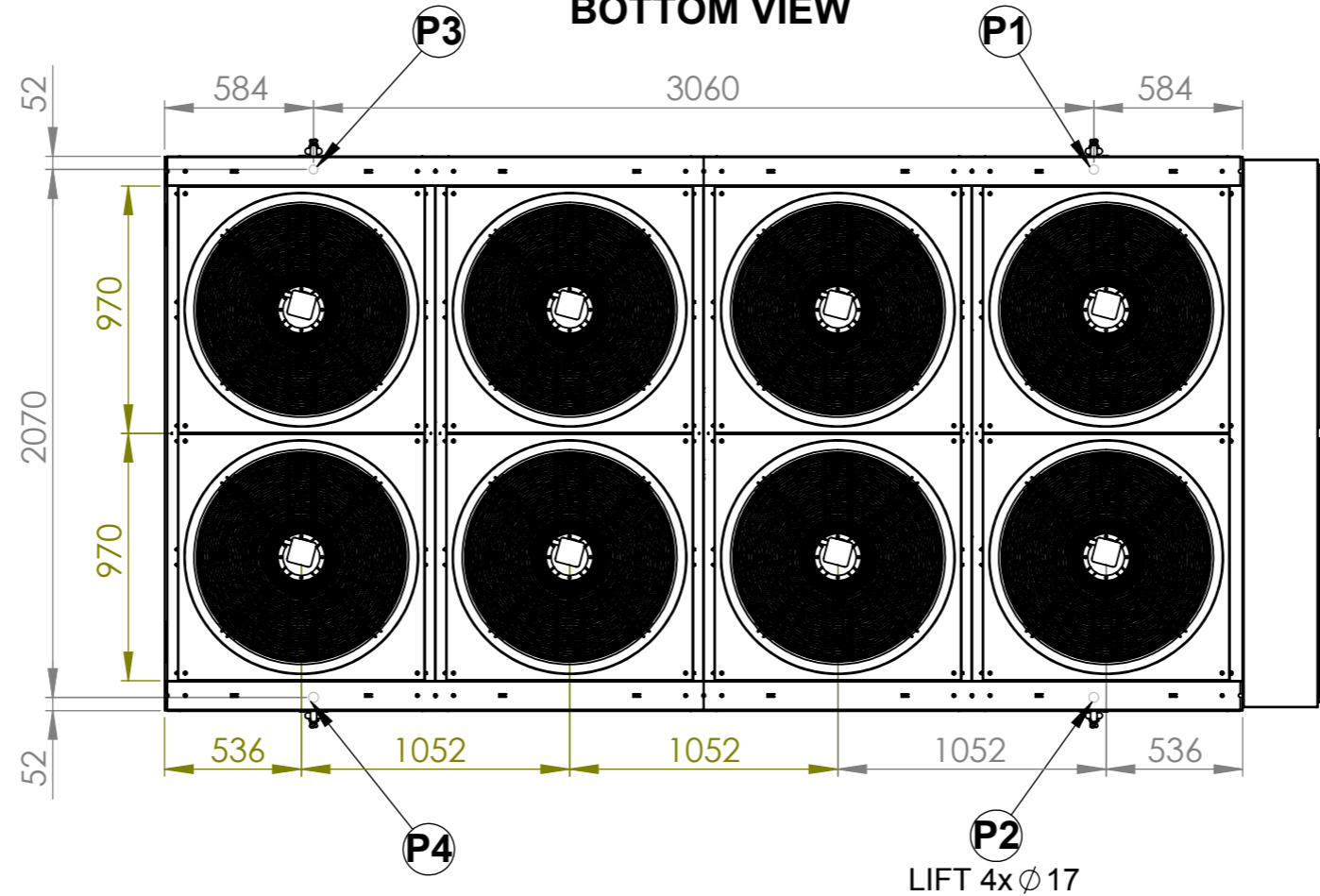

YLRA 300-330

NOTES:
A B C D E-WATER CONNECTION 3" GAS M Ø 88,9mm
F - ELECTRICAL POWER SUPPLY
I - GAUGE KIT (ACCESSORY)
L - MAIN SWITCH
M - CONTROL KEYPAD / DISPLAY

OPTIONAL
N- DESUPERHEATER WATER INLET Ø 1" GAS M
O- DESUPERHEATER WATER OUTLET Ø 1" GAS M

P1, P2, P3, P4 AVM POSITION

HYDRAULIC OPTION	WATER IN	WATER OUT
STD	B	E
1P/2P	A	C
1PT/2PT	A	D